

GCSE (9–1) Mathematics J560/03 Paper 3 (Foundation Tier)

Sample Question Paper

Date – Morning/Afternoon

Time allowed: 1 hour 30 minutes



You may use:

- A scientific or graphical calculator
- Geometrical instruments
- Tracing paper



First name				
Last name				
Centre number				
Candidate number				

INSTRUCTIONS

- Use black ink. You may use an HB pencil for graphs and diagrams.
- Complete the boxes above with your name, centre number and candidate number.
- Answer **all** the questions.
- Read each question carefully before you start to write your answer.
- Where appropriate, your answers should be supported with working. Marks may be given for a correct method even if the answer is incorrect.
- Write your answer to each question in the space provided.
- Additional paper may be used if required but you must clearly show your candidate number, centre number and question number(s).
- Do **not** write in the bar codes.

INFORMATION

- The total mark for this paper is **100**.
- The marks for each question are shown in brackets [].
- Use the π button on your calculator or take π to be 3.142 unless the question says otherwise.
- This document consists of **20** pages.

Answer **all** the questions

1 (a) Solve.

(i) $2x = 18$

(a)(i) $x = \dots\dots\dots$ [1]

(ii) $x + 2 = 5$

(ii) $x = \dots\dots\dots$ [1]

(iii) $\frac{x}{3} = 15$

(iii) $x = \dots\dots\dots$ [1]

(b) (i) Find the value of t when $g = 4$ and $h = 7$.

$$t = 12g - 5h$$

(b)(i) $t = \dots\dots\dots$ [2]

(ii) Rearrange to make r the subject.

$$4r - p = q$$

(ii) $\dots\dots\dots$ [2]

- 2 Cambury Council asked 60 customers what they thought of the local leisure centre. The results are shown in this bar chart.

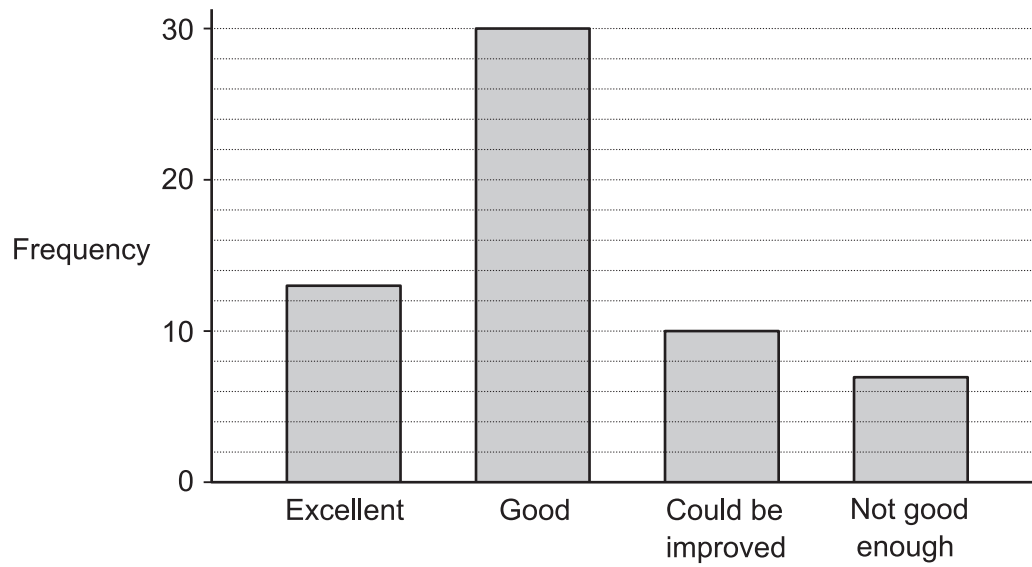

Draw and label a pie chart to represent this data.

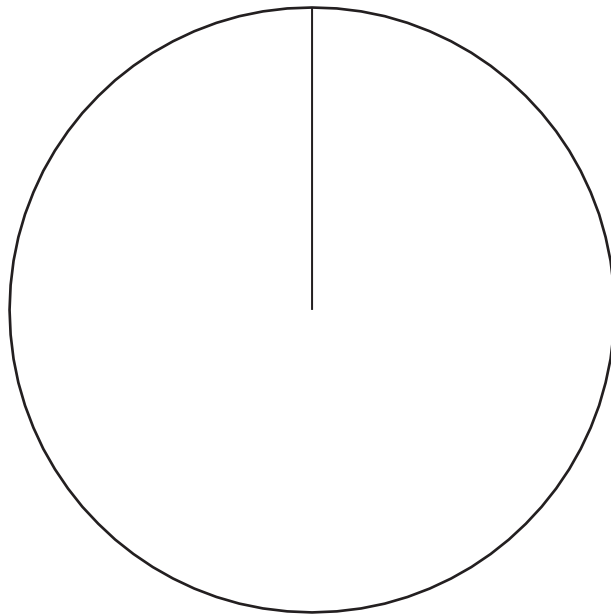

[5]

3 (a) How many 20p coins would you need to make up £7000?

(a) [2]

(b) Each 20p coin weighs 5g.

Lizzie says

I can lift £7000 worth of 20p coins.

Is Lizzie's claim reasonable?

Show your working and state any assumptions you have made.

.....
..... [4]

(c) How have any assumptions you have made affected your answer to part (b)?

..... [1]

4 Antonio works Monday, Tuesday and Wednesday.

He starts work at 4.00 pm and finishes at 10.30 pm.
Antonio is paid £10 per hour on weekdays.

One week, he also works for 4 hours on Sunday.
He is paid 50% more on Sundays.

How much does Antonio earn altogether this week?

£ [6]

5 Darren says

I can run 100 m in 15 seconds, so I should be able to run 800 m in 120 seconds.

Do you think that he would take more or less than 120 seconds to run 800 m?
Explain your answer, with reference to any assumptions Darren has made.

.....
.....
.....
..... [3]

- 6 Jo makes a pendant from a rectangular piece of silver.

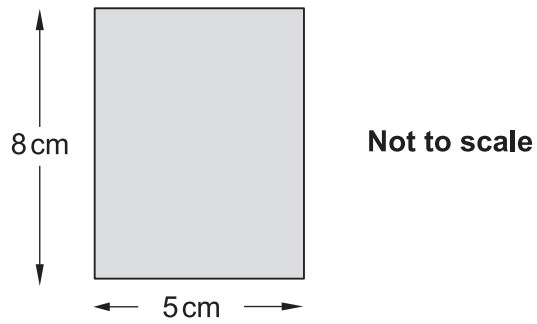

- (a) Work out the area of this rectangle.

(a) cm² [1]

- (b) To complete the pendant, Jo cuts two semicircles of radius 1 cm from the rectangle, as shown below.

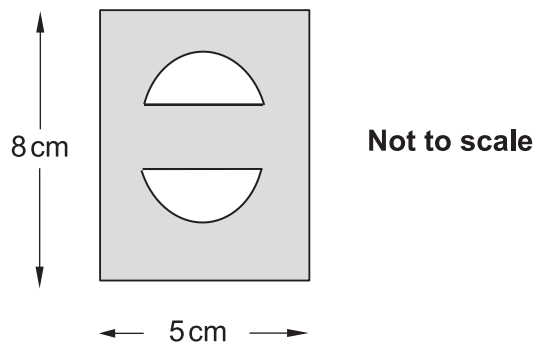

Show that the shaded area is 36.9 cm² correct to three significant figures.

[4]

(c) The silver Jo uses is 2 mm thick.

Find the volume of silver in the pendant.
Give your answer in cm^3 .

(c) cm^3 [3]

- 7 PQRS is a rectangle.
 A, B, C and D are points on SP, PQ, QR and RS respectively.
 AC is the line of symmetry for the diagram.

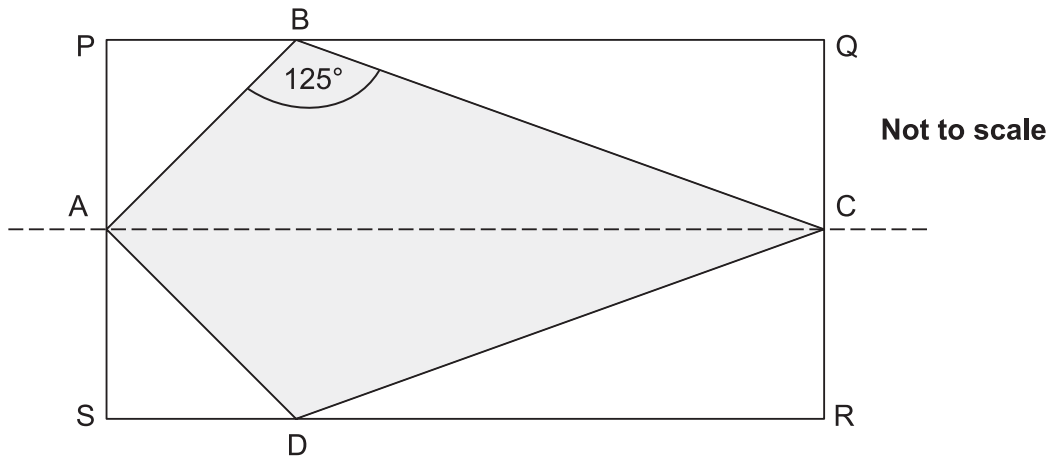

- (a) Angle $ABC = 125^\circ$.

Write down the size of angle ADC .

(a) Angle $ADC = \dots\dots\dots^\circ$ [1]

- (b) AP is the same length as PB.

Work out the size of angle BCD .
 Show your reasoning clearly.

(b) Angle $BCD = \dots\dots\dots^\circ$ [4]

8 (a) The n th term of a sequence is given by $3n + 5$.

Explain why 21 is not a term in this sequence.

.....
..... [2]

(b) Here are the first three terms in a sequence.

1 2 4

This sequence can be continued in different ways.

(i) Find one rule for continuing the sequence and give the next two terms.

Rule 1
Next two terms [2]

(ii) Find a second rule for continuing the sequence and give the next two terms.

Rule 2
Next two terms [2]

9 Three friends, Ann (A), Bob (B) and Carol (C), go on holiday together.

(a) They book a row of three seats on the plane.

When they arrive at the plane they sit in a random order.

(i) List all the different orders they could sit on the three seats.
The first one has been done for you.

Seat 1	Seat 2	Seat 3
A	B	C

[2]

(ii) What is the probability that Ann and Carol sit next to each other?

(a)(ii) [1]

(iii) What is the probability that Bob sits in seat 1 with Ann next to him?

(iii) [1]

- (b) Ann, Bob and Carol have a total budget of £500 to rent a holiday apartment. The apartment normally costs £50 per night, but they can get a 20% discount if they book early.

Calculate how many extra nights they can stay in the apartment if they book early.

(b) nights [4]

10 Calculate.

(a) $\sqrt{3136}$

(a) [1]

(b) $\sqrt[4]{625}$

(b) [1]

(c) 5^{-2}

(c) [1]

11 Ema has done some calculations.

For each calculation, explain how you know the answer is wrong without working out the correct answer.

(a) $0.38 \times 0.26 = 0.827$

.....
 [1]

(b) $\frac{3}{4} + \frac{2}{3} = \frac{5}{7}$

.....
 [1]

12 Shinya’s internet service provider gives him a graph of his internet usage in the first part of February.

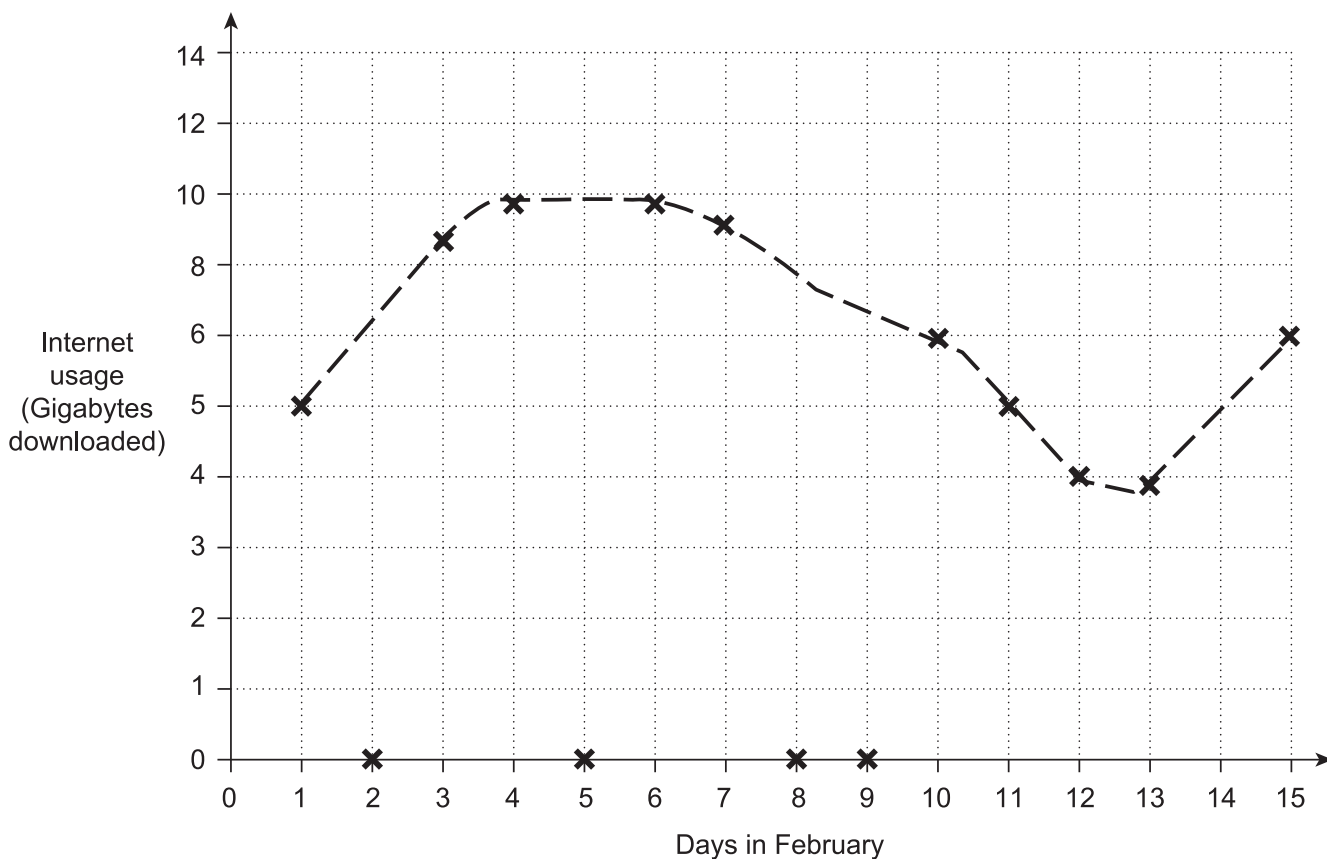

State two reasons why this graph is misleading.

- 1
- 2

[2]

- 13 (a) Mia cycled 23 km, correct to the nearest km.

What is the least distance Mia could have cycled?

(a) km [1]

- (b) A number x , rounded to one decimal place, is 4.7.
So the error interval for x is given by $4.65 \leq x < 4.75$.

- (i) A number y , rounded to **two** decimal places, is 4.13.

Write down the error interval for y .

(b)(i) [2]

- (ii) A number z , rounded to two significant figures, is 4700.

Write down the error interval for z .

(ii) [2]

- 14 This frequency diagram summarises the number of minutes Astrid's train was late over the last 50 days.

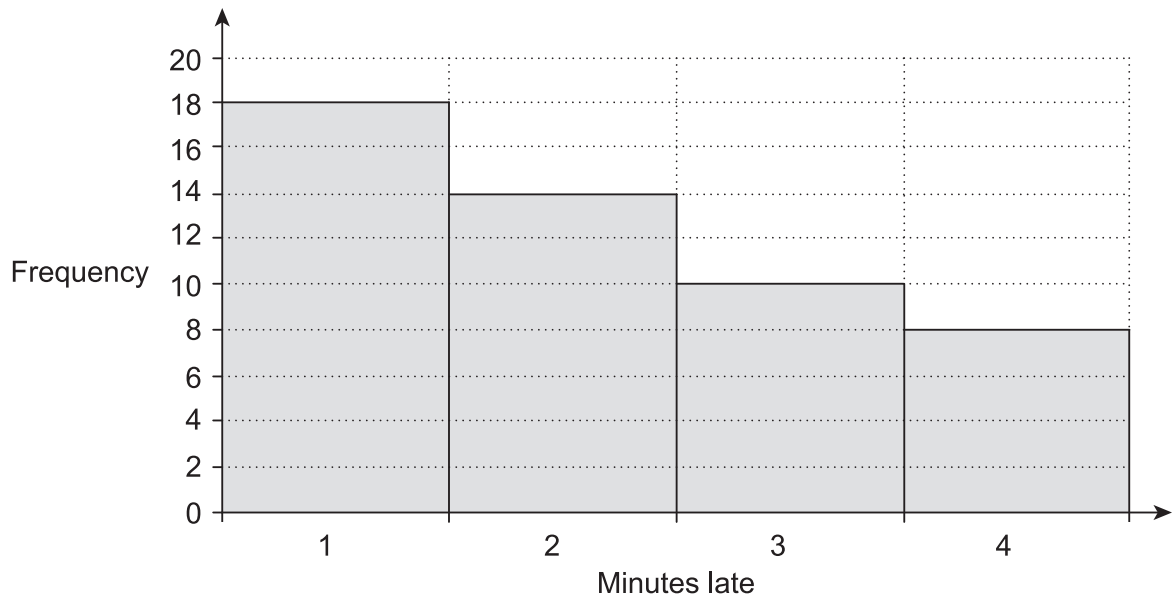

- (a) Use information from this diagram to estimate the probability that her train will be 4 minutes late tomorrow.

(a) [2]

- (b) Explain whether your answer to part (a) gives a reliable probability.

.....
 [1]

15 In the diagram below, AE and BD are straight lines.

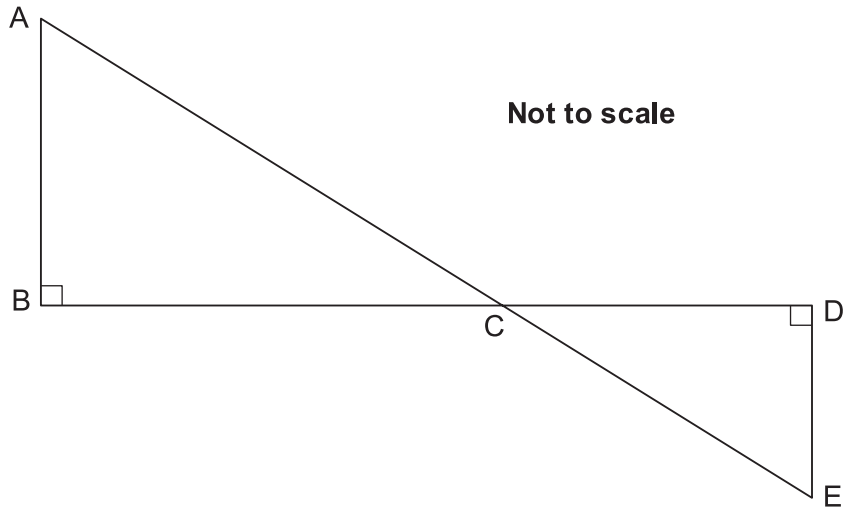

(a) Show that triangles ABC and EDC are similar.

.....

.....

.....

.....

.....

.....

.....

[3]

(b) The length DE is 3.5m.
The ratio $BC : CD = 3 : 1$.

Find the length AB.

(b) m [2]

16 Leo is using these numbers to make a new number.

11

1

3

6

- He can use brackets, +, −, × and ÷ as often as he wishes.
- He cannot use any number more than once.
- He cannot use powers.
- He cannot put numbers together, e.g. he can't use 136.

What is the biggest number he can make?

Show how he can make this number.

.....

.....

.....

..... [4]

17 180 g of copper is mixed with 105 g of zinc to make an alloy.

The density of copper is 9 g/cm^3 .

The density of zinc is 7 g/cm^3 .

(a) Work out the volume of copper used in the alloy.

(a) cm^3 [2]

(b) What is the density of the alloy?

(b) g/cm^3 [4]

18 (a) (i) Solve.

$$5x + 1 > x + 13$$

(a)(i) [3]

(ii) Write down the largest integer that satisfies $5x - 1 < 10$.

(ii) [1]

(b) Solve.

$$3x^2 = 75$$

(b) $x =$ [2]

(c) Solve.

$$4x + 3y = 5$$

$$2x + 3y = 1$$

(c) $x =$

$y =$

[3]

19 Here are the interest rates for two accounts.

Account A
Interest: 3% per year compound interest.
No withdrawals until the end of three years.

Account B
Interest: 4% for the first year, 3% for the second year and 2% for the third year.
Withdrawals allowed at any time.

Derrick has £10 000 he wants to invest.

- (a) Calculate which account would give him most money if he invests his money for 3 years. Give the difference in the interest to the nearest penny.

(a) Account by p [5]

- (b) Explain why he might **not** want to use Account A.

.....
 [1]

Copyright Information

OCR is committed to seeking permission to reproduce all third-party content that it uses in the assessment materials. OCR has attempted to identify and contact all copyright holders whose work is used in this paper. To avoid the issue of disclosure of answer-related information to candidates, all copyright acknowledgements are reproduced in the OCR Copyright Acknowledgements Booklet. This is produced for each series of examinations and is freely available to download from our public website (www.ocr.org.uk) after the live examination series.

If OCR has unwittingly failed to correctly acknowledge or clear any third-party content in this assessment material, OCR will be happy to correct its mistake at the earliest possible opportunity.

For queries or further information please contact the Copyright Team, First Floor, 9 Hills Road, Cambridge CB2 1GE.

OCR is part of the Cambridge Assessment Group; Cambridge Assessment is the brand name of University of Cambridge Local Examinations Syndicate (UCLES), which is itself a department of the University of Cambridge.